

| REV | ZONE | REVISION | DATE | APPD. |
|-----|------|----------|------|-------|
| | | | | |
| | | | | |
| | | | | |

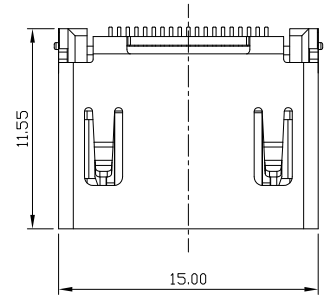

C - SUD-110M2*-* * *

Series _____ Shell
 Type _____ N : Nickel Plated
 Color _____ Gold Plated
 B : Black 0 : Gold Flash
 Material _____ 1 : 5u"
 L : LCP 2 : 15u"
 3 : 30u"

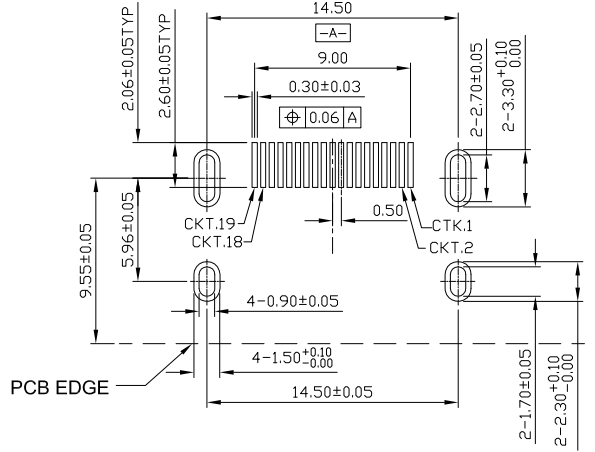
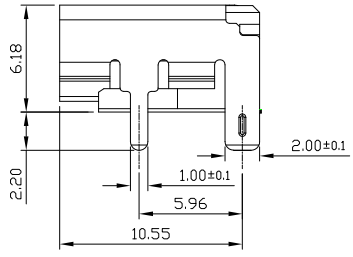
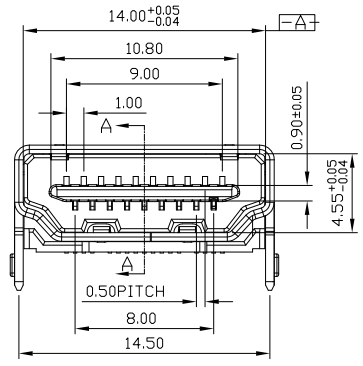

RECOMMENDED PCB LAYOUT TOP VIEW

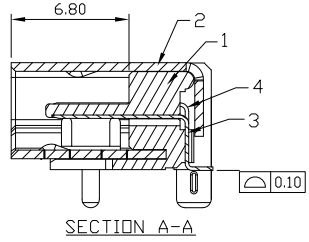
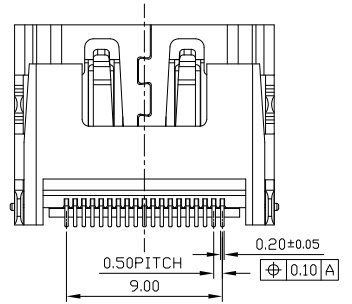

| NO. | NAME | MATERIAL | PLATING |
|-----|-----------|--------------|-------------|
| 1 | HOUSING | LCP | |
| 2 | SHELL | Alloy | Ni-Plated |
| 3 | CONTACT 1 | Copper Alloy | Gold-Plated |
| 4 | CONTACT 2 | Copper Alloy | Gold-Plated |



| | | | | | | | |
|--------------|--------------------|-------------|------------|--|---|--|----------|
| COMPUTER NO. | | | UNIT | SCALE | PART NAME | | |
| D:\DWG\HM10B | | | mm | 1:1 | HDMI RECEPTACLE, R/A, SMT TYPE 0.5mm PITCH, 19 POS. | | |
| APPD. | CKD. | DWG. | DATE | TOLERANCE | | | |
| | Aaron | Eric | 2010-12-02 | 0.000mm ± 0.075mm 0.00 mm ± 0.20 mm 0.0 mm ± 0.25 mm | | | |
| MODEL | C-SUD-110M2*-* * * | PAGE 1 OF 1 | | | | | REV. A.0 |