

REV	ZONE	REVISION	DATE	APPD.

C-SUD-110M2T * -L * N

Series _____ Shell
 Type _____ N : Nickel Plated
 Color _____ Gold Plated
 B : Black 0 : 3u"
 Material _____ 1 : 5u"
 L : LCP 2 : 15£g"
 3 : 30£g"

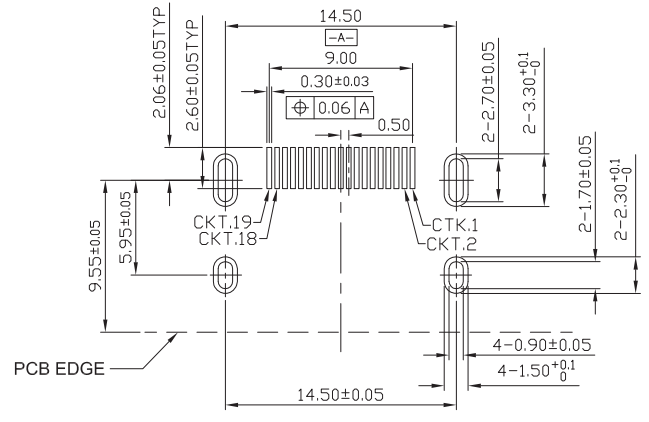
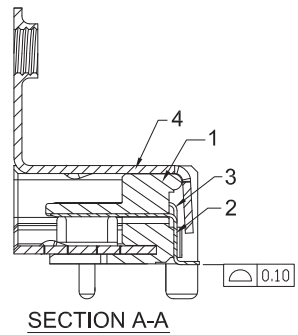
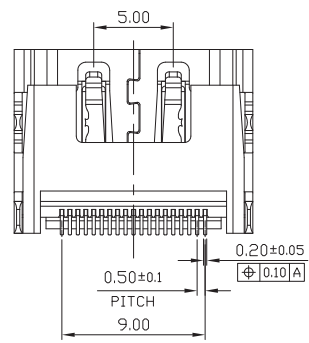
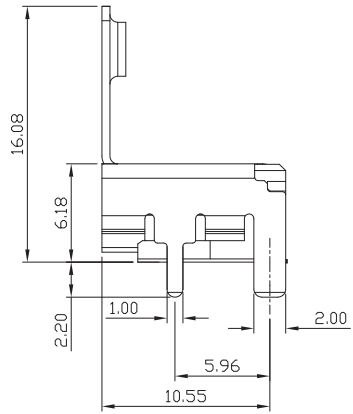
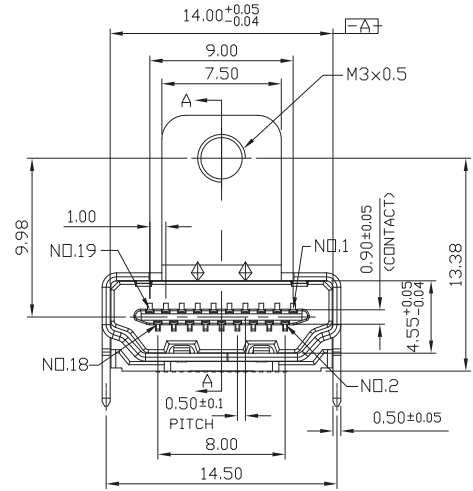
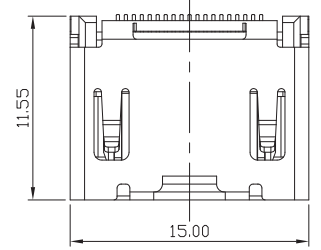

RECOMMENDED PCB LAYOUT
TOP VIEW

NO.	NAME	MATERIAL
1	HOUSING	LCP
2	CONTACT 1	COPPER ALLOY
3	CONTACT 2	COPPER ALLOY
3	SHELL	ALLOY

CHAMPWAY 冠泰電子有限公司
CHAMPWAY ELECTRONICS CO., LTD.

COMPUTER NO.			UNIT	SCALE	PART NAME	
D:\DWG\SUD-110MT			mm	1:1	HDMI A Type 19P/F 90° SMT With Flange	
APPD.	CKD.	DWG.	DATE	TOLERANCE	PART NO.	REV.
MODEL	C-SUD-110M2T * -L * N	PAGE 1 OF 1	Aaron Lucy	2010-12-27	0.000mm ± 0.075mm 0.00 mm ± 0.20 mm 0.0 mm ± 0.25 mm	A.0